

The Invisible Engine of the 21st Century

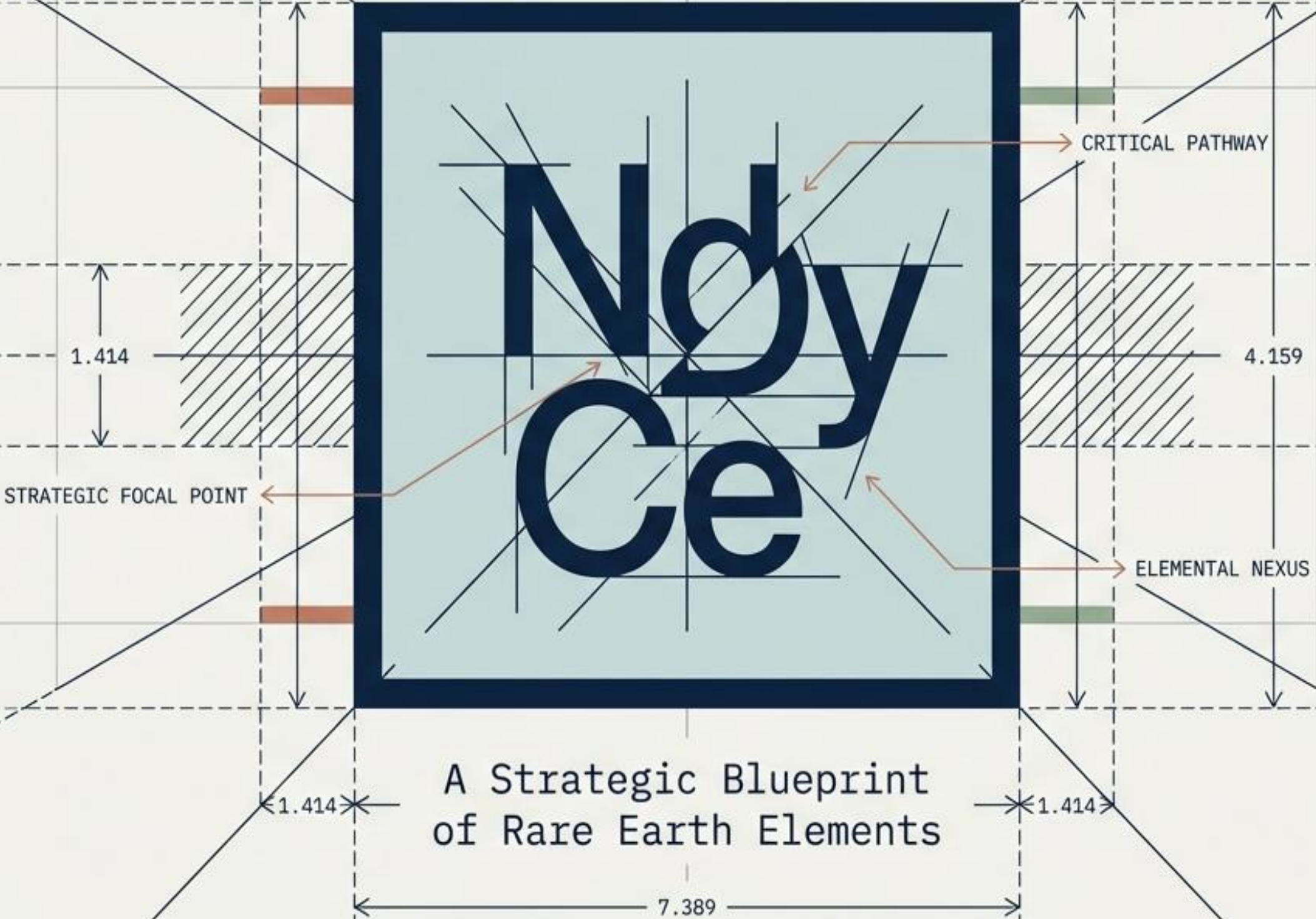

A Strategic Blueprint of Rare Earth Elements

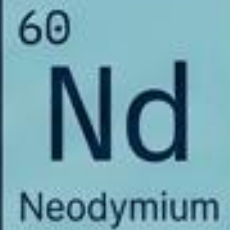

Drive Motor (EV)

1 to 2 kg of NdFeB magnets per motor.

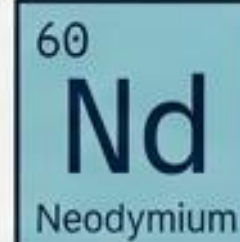

Generator (Wind Turbine)

300 kg required per megawatt of capacity.



Display Screen

Enables vibrant red and blue phosphors.

Medical Context



Medical Scanner

Vital contrast agent for MRI scans.

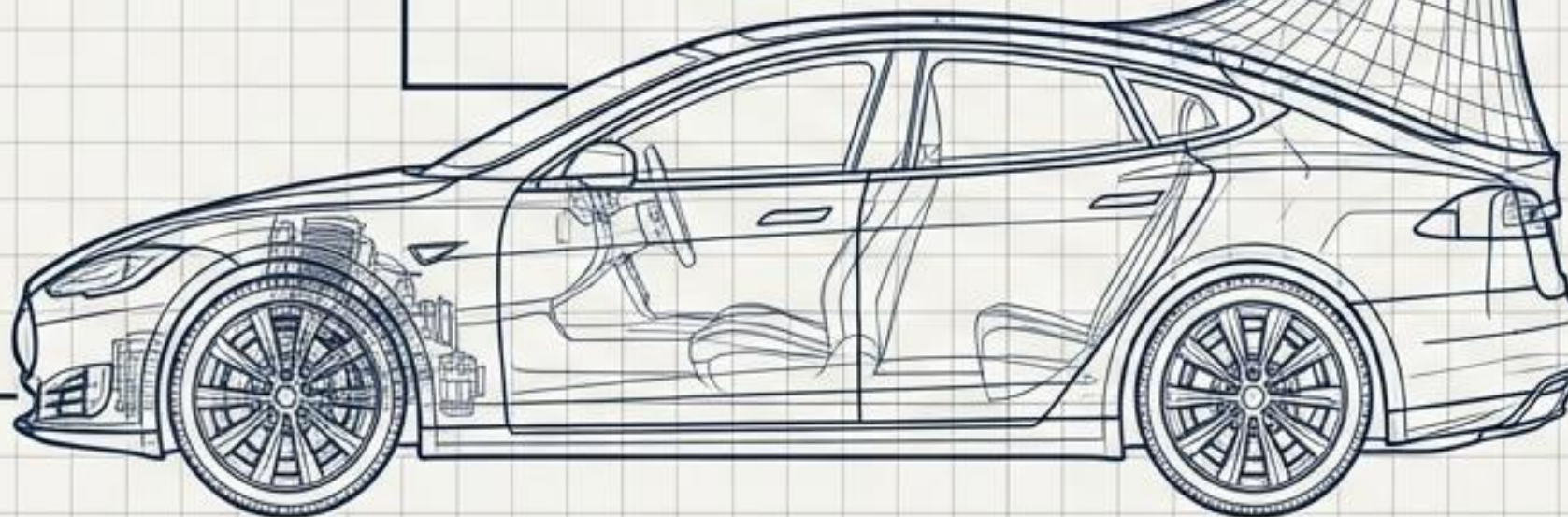

Core Insight: All of these technologies share a silent, indispensable ingredient: a family of 17 chemically unique metals known as Rare Earth Elements.

The Misnomer of “Rare”

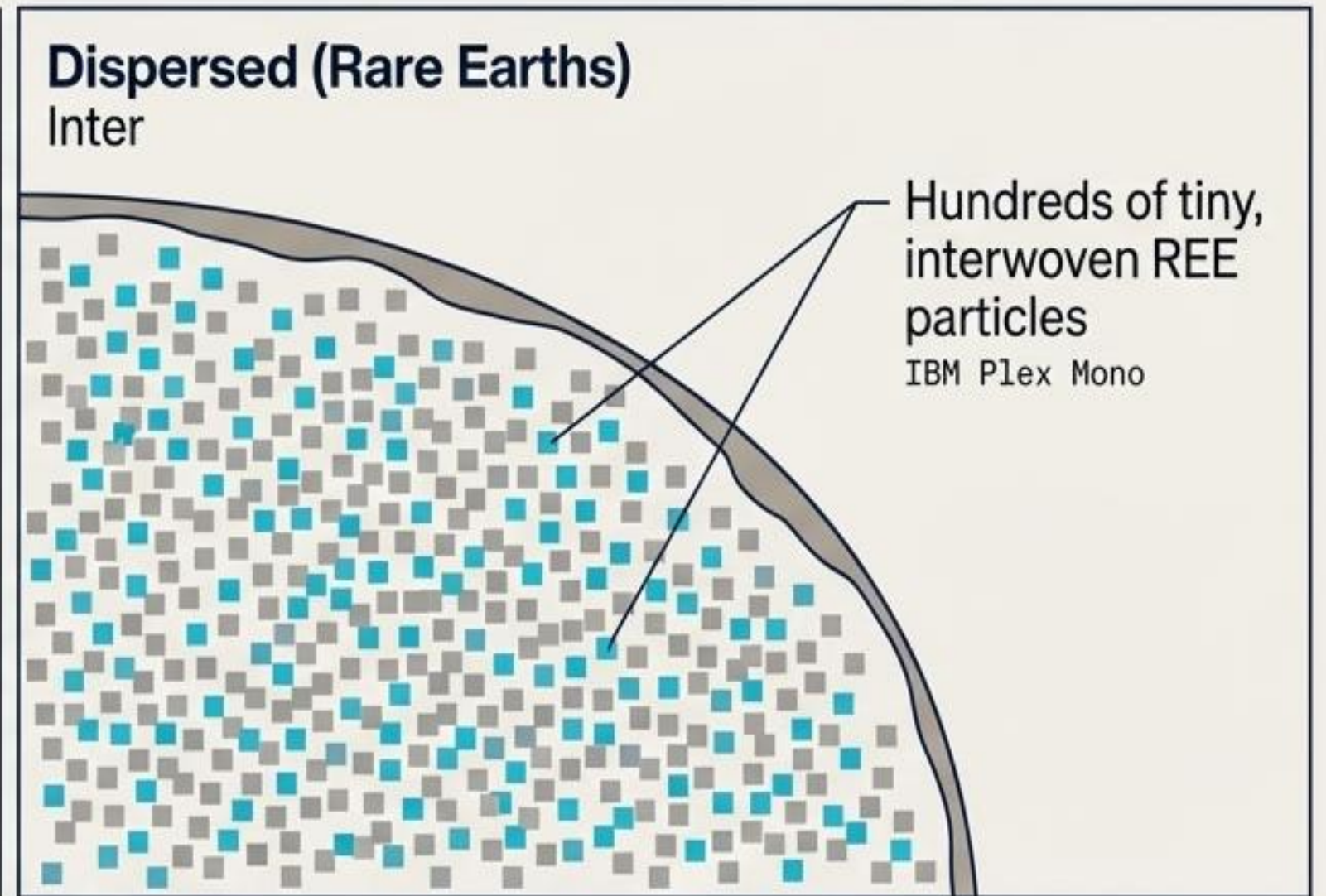
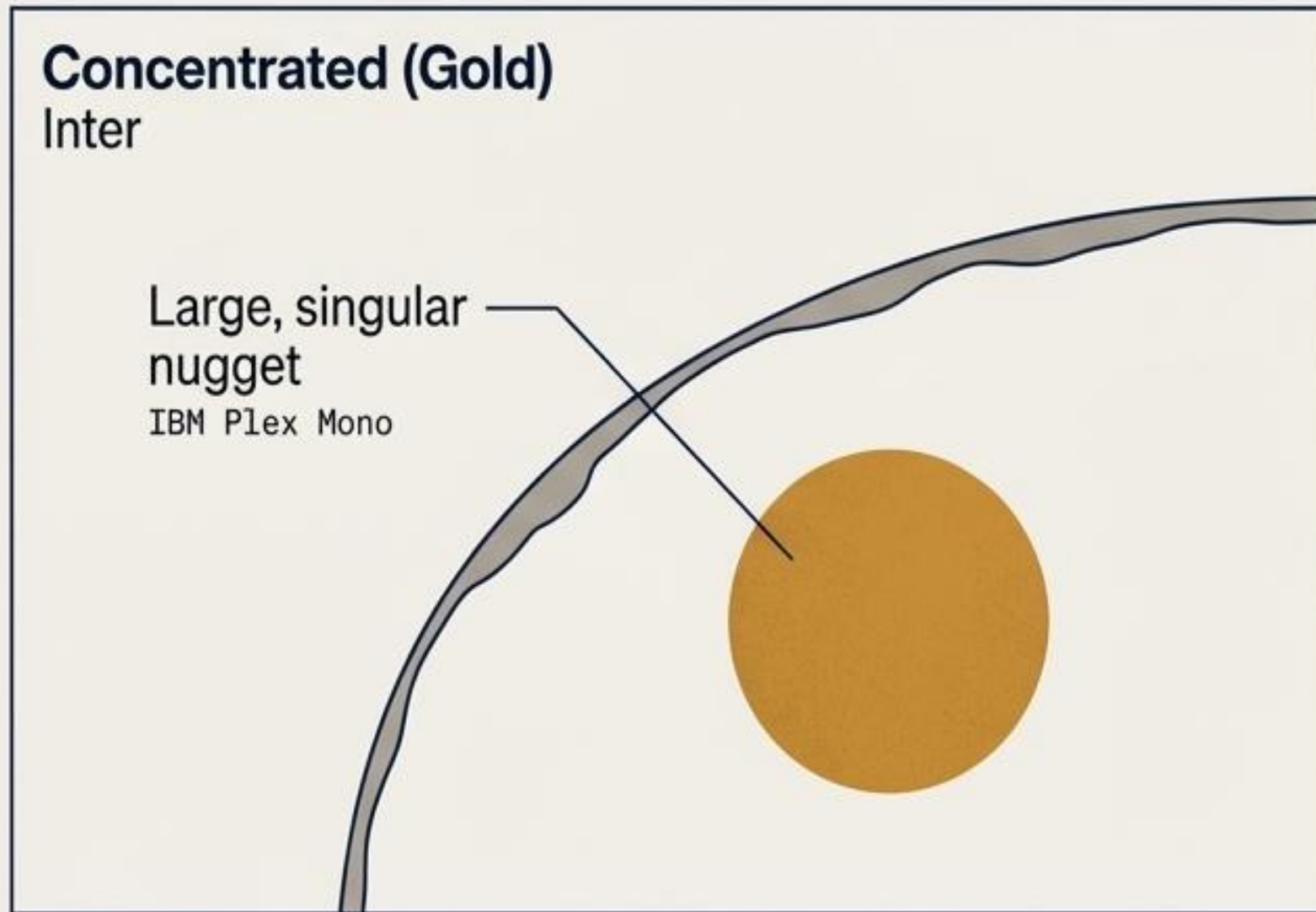

Cerium is as abundant in the Earth's crust as copper or nickel.

Even the least abundant REEs (Thulium, Lutetium) are nearly 200 times more common than gold.

Takeaway: The challenge is not scarcity.

REEs almost never appear in easily mineable, concentrated deposits. They are geologically dispersed and chemically locked together, making separation technically demanding and highly expensive.

The Application Matrix: Categorizing the 17 Elements

The Magnetics



- Use: High-strength permanent magnets, EV motors, wind turbines.

The Luminescents

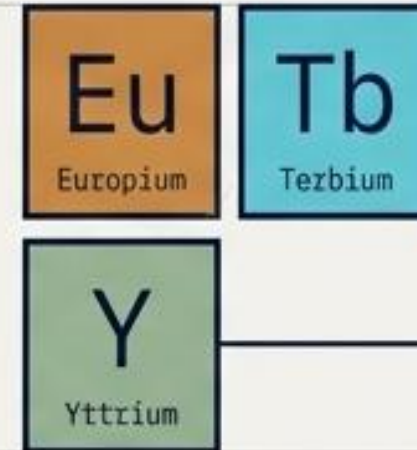

- Use: LED screens, color displays, energy-saving bulbs, anti-counterfeiting.

The Catalysts

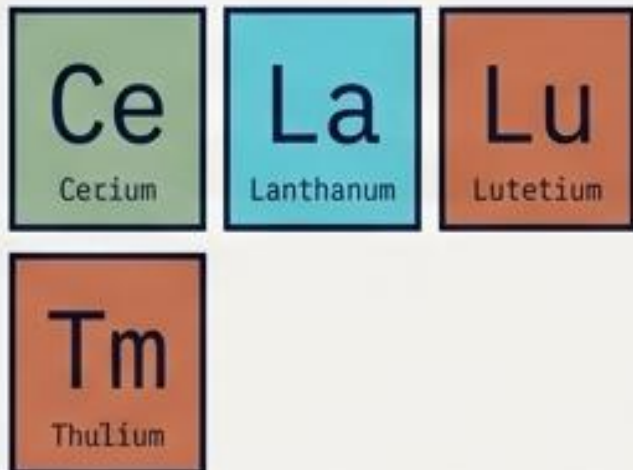

- Use: Petroleum refining, vehicle catalytic converters, glass polishing.

The Medicals & Specialties

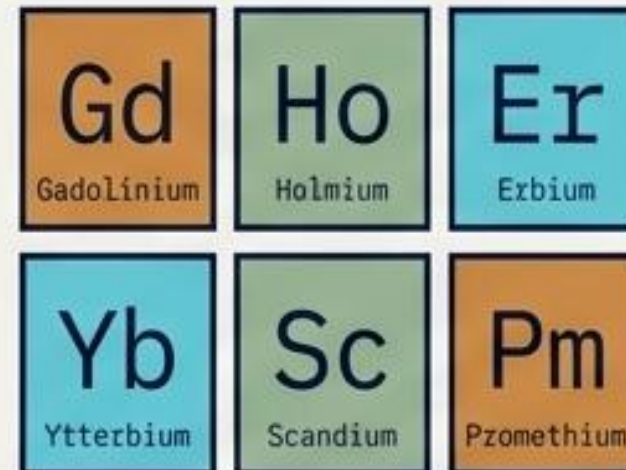

- Use: MRI contrast agents, surgical lasers, atomic clocks, aerospace alloys.

The Rockstar Element Diagnostic

Nd

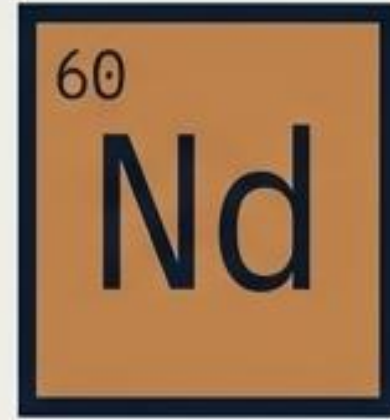

Subhead
Neodymium

Nickname
The Magnet

Body
Creates the world's most powerful permanent magnets (NdFeB). Accounted for 30.3% of global REE revenues in 2024.

Strategic Value:
CRITICAL

Dy

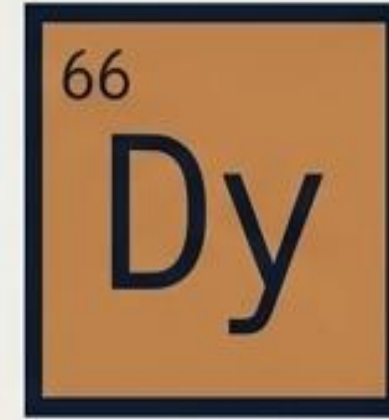

Subhead
Dysprosium

Nickname
The Quiet Enabler

Body
Additive that stabilizes Nd magnets at extreme temperatures.

Strategic Value:
CRITICAL

Ce

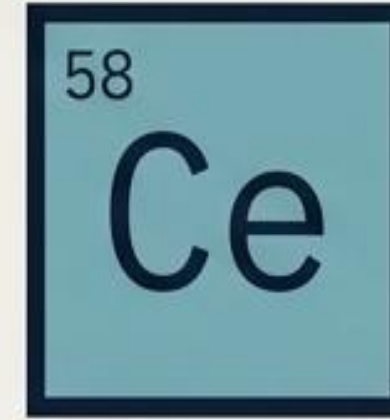

Subhead
Cerium

Nickname
The Unsung Hero

Body
The most abundant REE. Cleans vehicle exhaust, polishes glass.

Strategic Value:
HIGH

Eu



Subhead
Europium

Nickname
The Color Creator

Inter
Made the 1960s color TV revolution possible; vital for modern LEDs.

Strategic Value:
MEDIUM

Gd

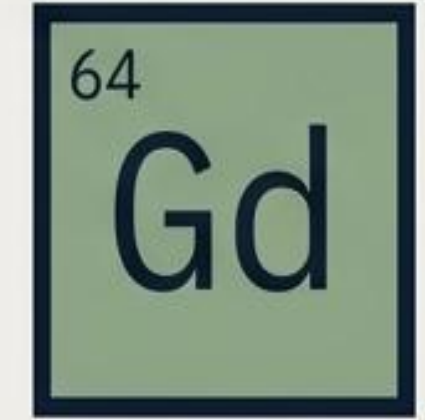

Subhead
Gadolinium

Nickname
The Clarifier

Inter
Injected as a contrast agent to make MRI scans visible to doctors.

Strategic Value:
HIGH

The Synergy of Power and Stability

Phase 1: The High-Heat Challenge

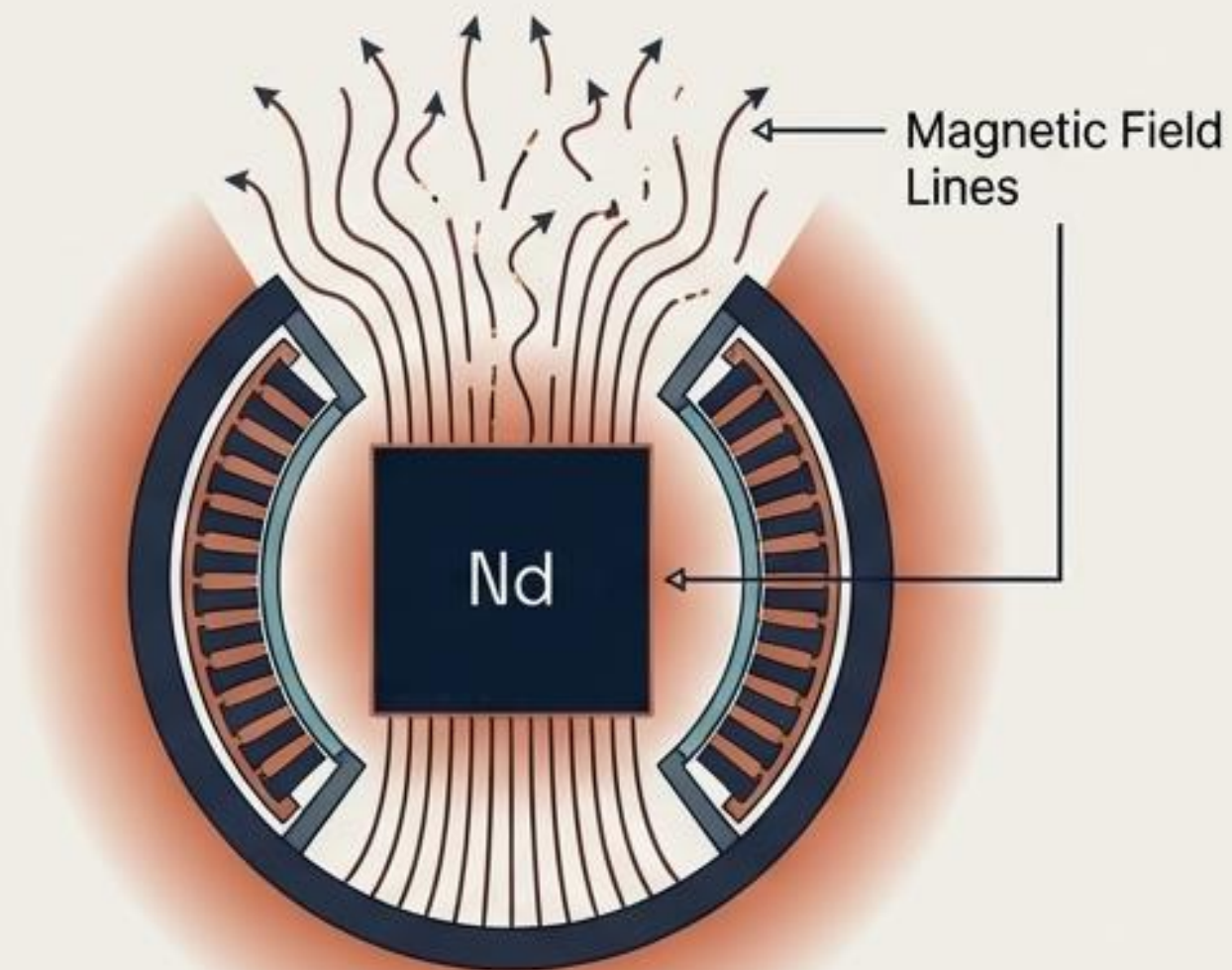

Neodymium creates unmatched magnetic power, but loses its magnetism under the intense heat of an EV motor or wind turbine.

Phase 2: The Dysprosium Solution

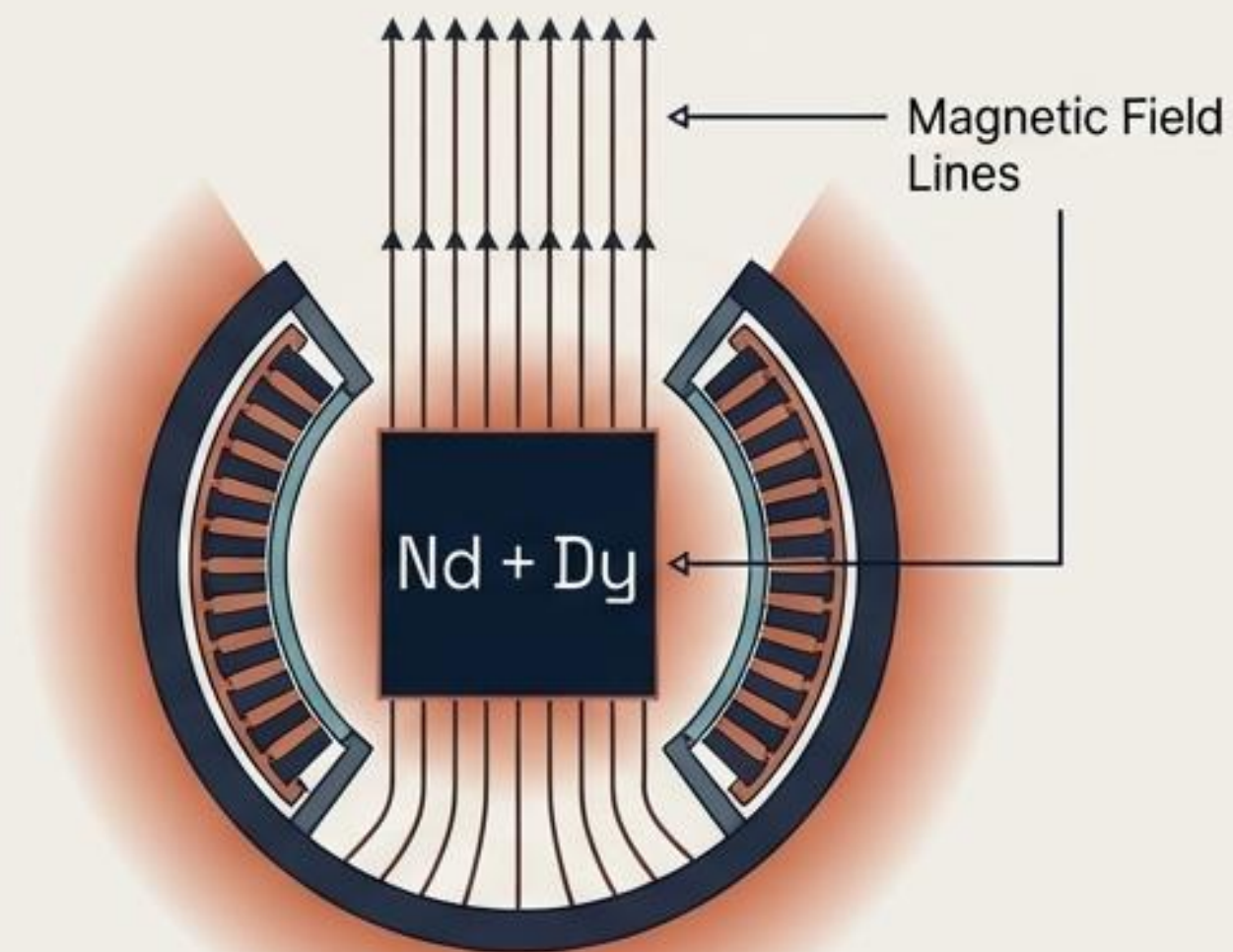

The Fix: Adding just 2–6% Dysprosium stabilizes the magnet at extreme temperatures, making Dy a non-negotiable strategic additive.

The Industry Demand Matrix

Market Valuation: \$3.95 billion (2024)
→ \$6.28 billion by 2030 (8.6% CAGR)

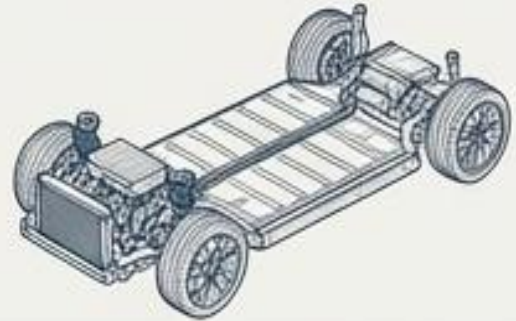

EVs & Automotive

EV sales topped 14.2M in 2023. Fleet transition drives massive NdFeB magnet demand.

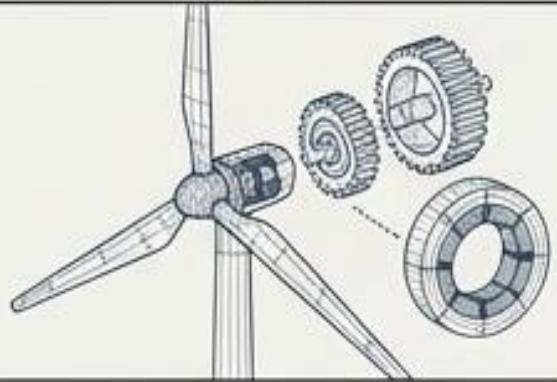

Wind Energy

Global capacity to double to >2,000 GW by 2030. Offshore direct-drive turbines are massively REE-intensive.

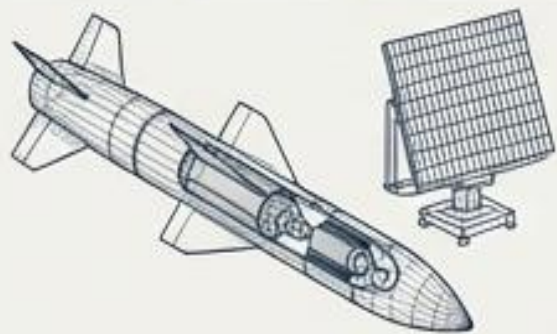

Defense

Critical for guided missiles (Sm-Co magnets), radar (Tb), and fighter jets. Supply disruption holds the highest economic risk penalty in the U.S.



Macro Projection: Global demand for magnetic REEs is projected to triple from 59 kilotons in 2022 to 176 kilotons by 2035.

The Geopolitical Chokehold

GLOBAL SUPPLY CONVERGENCE MAP



MINING

>60%

China mines approx 210,000 of 300,000 metric tons globally



PRIMARY EXTRACTION DOMINANCE

PROCESSING

>80%

China processes the vast majority of all refined rare earth elements



REFINING & SEPARATION CONTROL

MANUFACTURING

~90%

China produces the world's high-performance REE magnets



DOWNSTREAM COMPONENT MONOPOLY

THE WEAPONIZATION RISK:



In April 2025, China imposed stringent export controls on seven critical elements (including Dy, Gd, Tb, Lu), instantly complicating worldwide procurement.

The Anatomy of a Supply Bottleneck



CONCLUSION: A NEW MINE TAKES 10 TO 15 YEARS FROM DISCOVERY TO COMMERCIAL PRODUCTION.

The Supply-Demand Collision

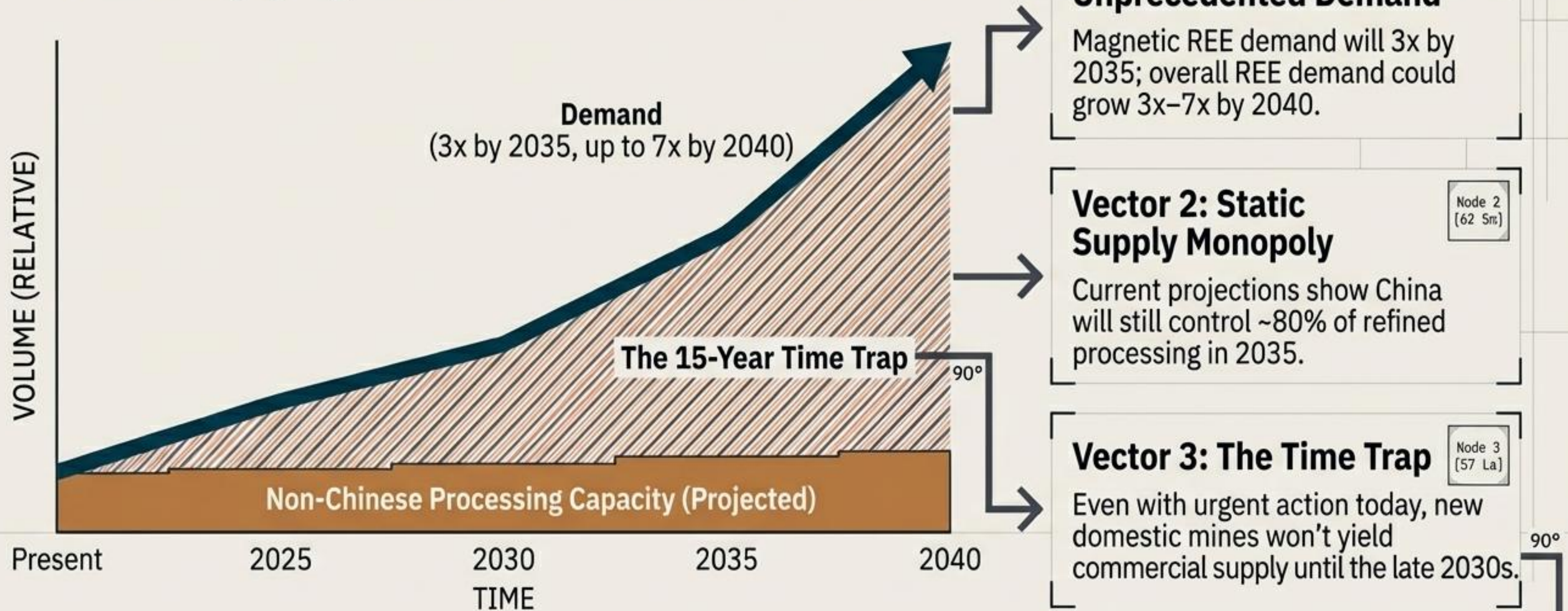

Synthesis: This collision transforms Rare Earth Elements from an industrial commodity into an urgent, non-negotiable national security crisis.

The Indian Paradox: A Sleeping Giant

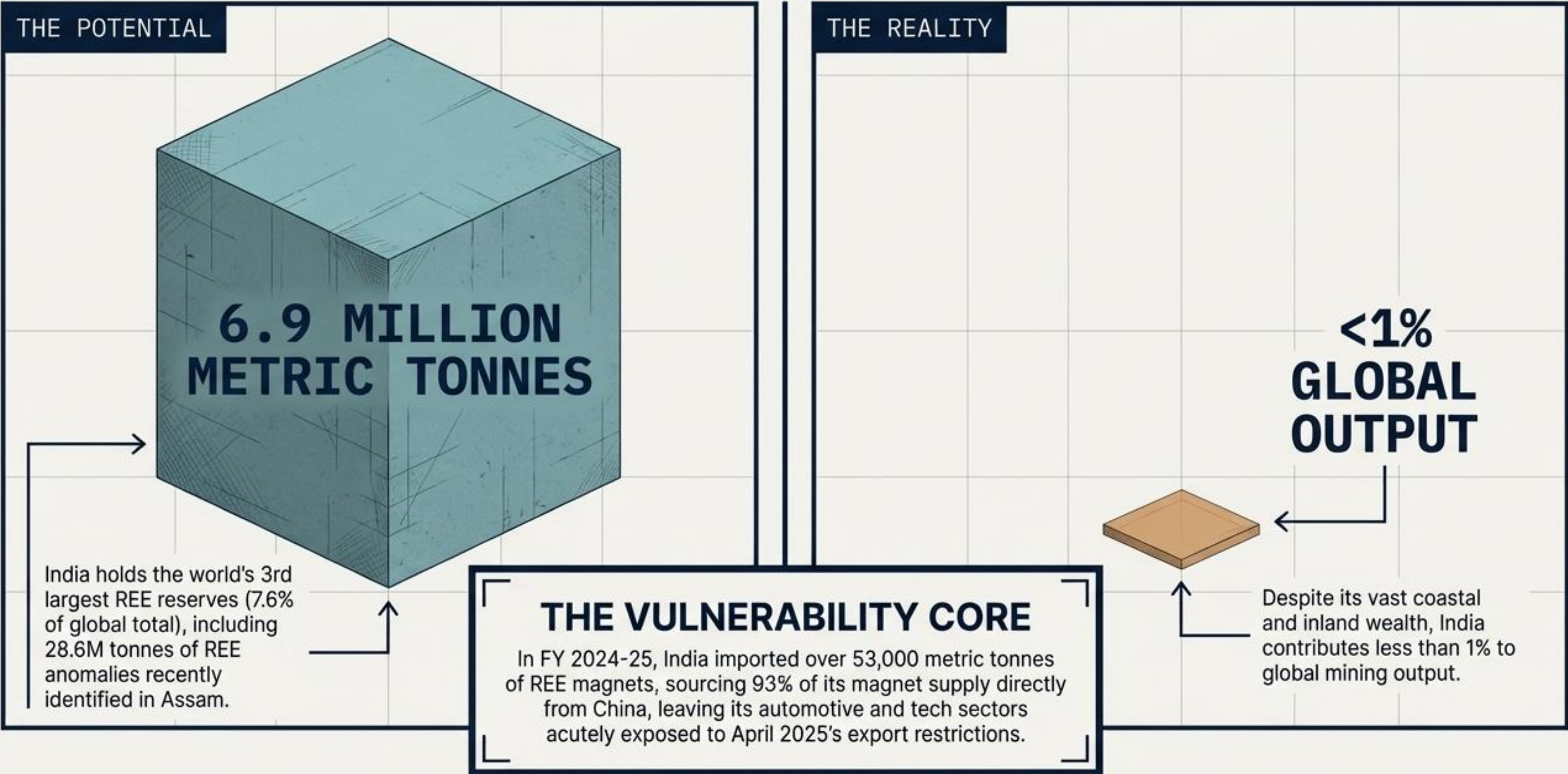

India's Blueprint for Independence

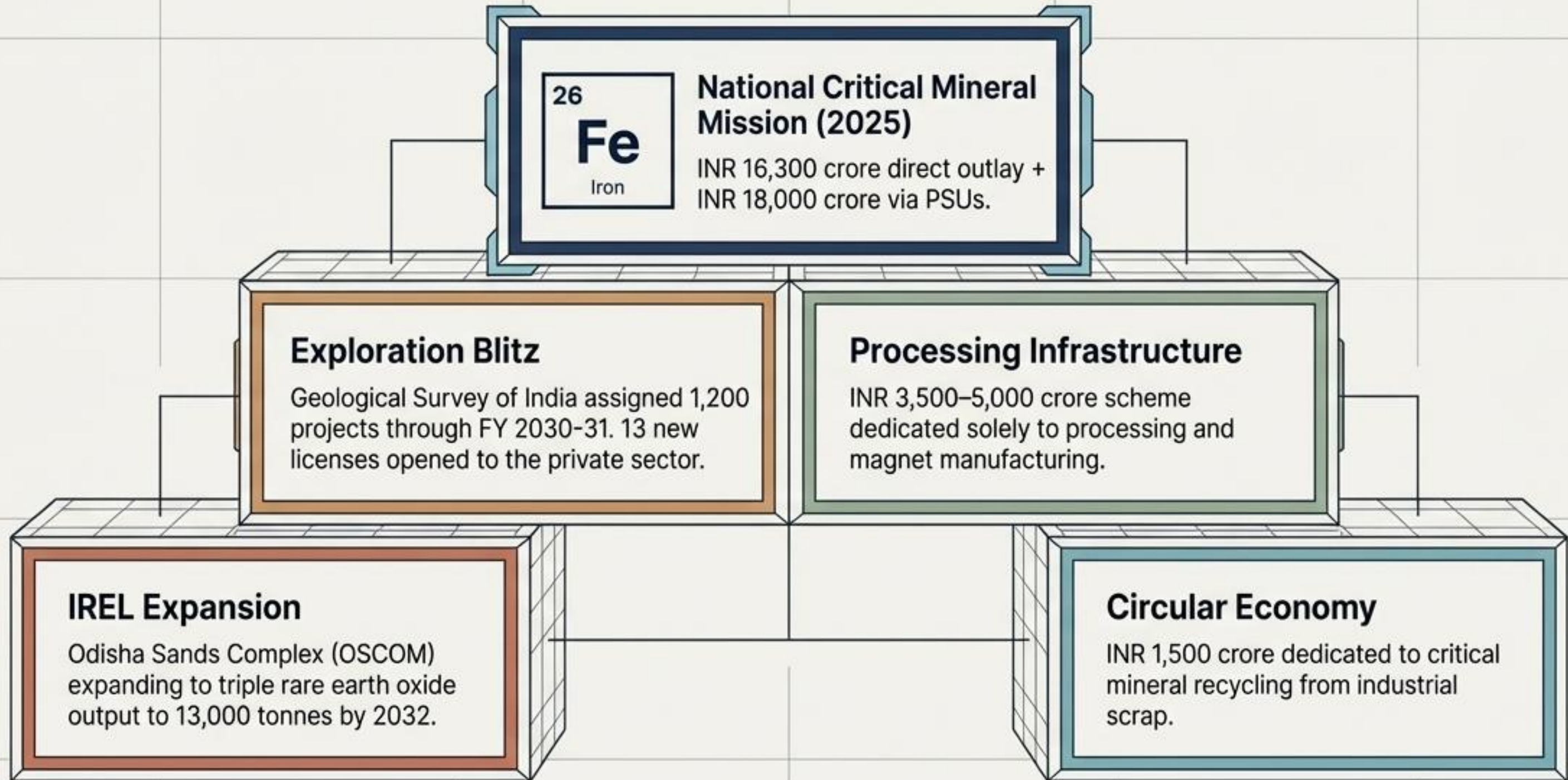

The Global Counter-Offensive



United States

IBM Plex Mono

MP Materials (Texas) launching America's first integrated REE magnet facility with **\$58.5M** in government backing.

USA Rare Earth (Oklahoma) investing \$100M for **4,800 TPA** capacity.

Australia

IBM Plex Mono

Lynas Rare Earths operating the largest non-Chinese processing facility, targeting zero-waste by 2030.

Allied Networks

IBM Plex Mono

India-Australia Critical Minerals Partnership (2022) & Canada Pact (2025).

14-country U.S.-led Minerals Security Partnership (MSP) coordinating to secure stable supply chains.

Urban Mining: The Next Frontier

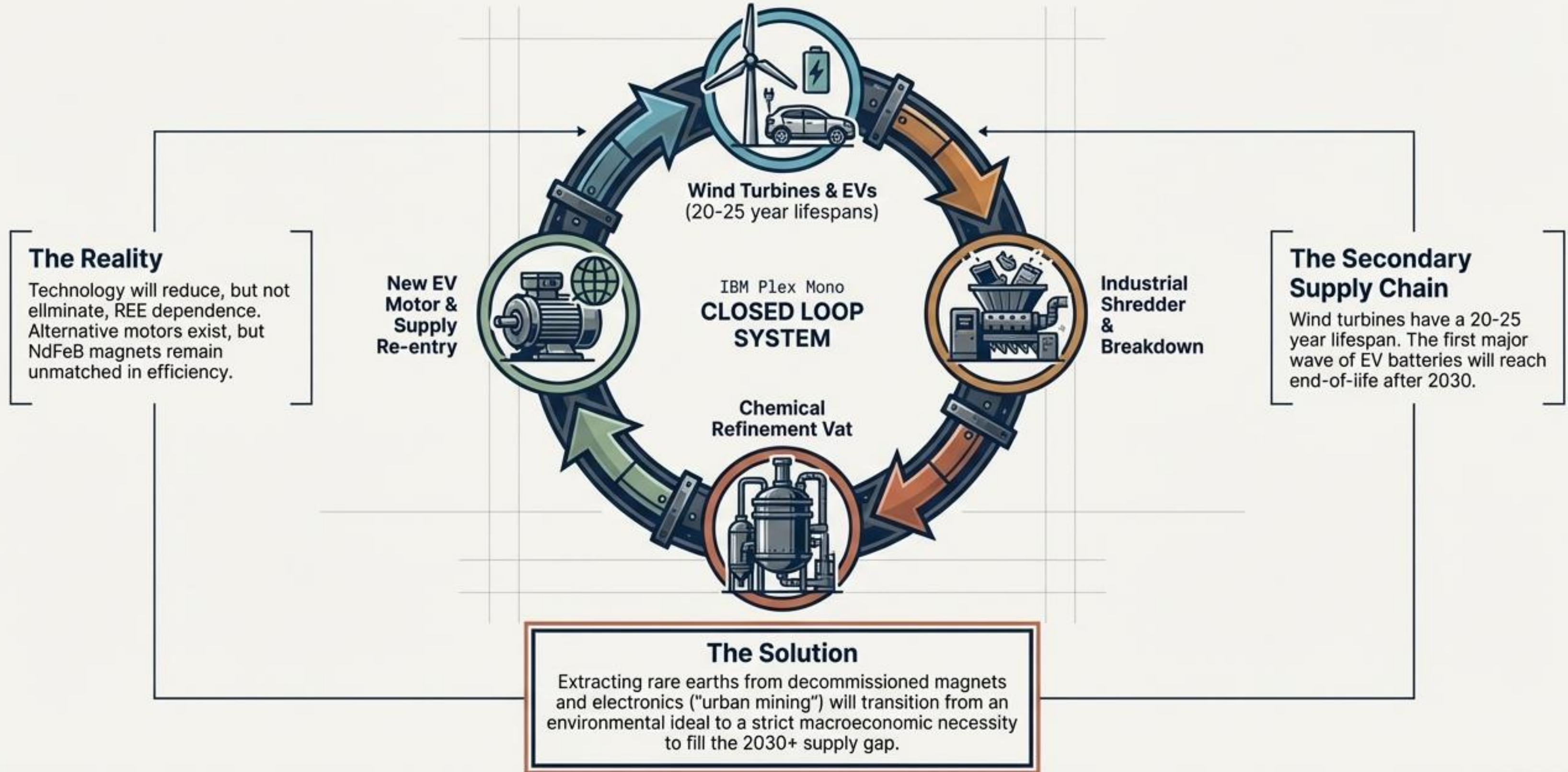



The Silent Backbone of Modernity

Rare earth elements are no longer a hidden geological curiosity. They are the building blocks of the clean energy transition, the engines of next-generation technology, and the flashpoints of modern geopolitics.

The era of rare earths as an invisible commodity is over. Their time as a primary driver of global security and technological supremacy has arrived.